

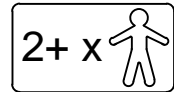

SQUARE BALE "TIE DOWN KIT" INSTRUCTIONS FOR BULL FLEX TARPS

IT IS RECOMMENDED TO HAVE TWO OR MORE PEOPLE PERFORM THIS INSTALLATION
(KIT CONTAINS: (40) 18' ROPES WITH SUPER CINCHES AND "J" HOOKS INSTALLED)



! INSTALL KIT PRIOR TO PLACING BULL FLEX TARP ON HAY STACK !

- 1 TAKE A LONG SECTION OF ROPE AND TIE TO EACH WEBBING LOOP ON BOTH SIDES OF THE BULL FLEX TARP.
(CONTINUE THIS PROCESS FOR ALL 18 WEBBING LOOPS ON EACH SIDE OF THE TARP, ADDITIONALLY TIE A ROPE ASSEMBLY TO EACH OF THE WEBBING STRAPS THAT PASS THROUGH THE ENDS OF THE TARPS.)
- 2 ONCE ALL ROPES ARE INSTALLED PLACE TARP ON STACK
- 3 LOOSEN KNOT ON SUPER CINCH AND SLIDE IT TO JUST ABOVE HEAD LEVEL ON STACK.
- 4 SECURE EACH END CORNER STRAP WITH A "J" HOOK BY FIXING EACH HOOK TO THE TWINE OF A BOTTOM BALE AND THEN TIGHTEN WITH A SUPER CINCH.
- 5 ONCE BOTH ENDS ARE SECURE, DO THE SAME FOR THE MIDDLE ROPES TIGHTENING WITH 300 - 400 LBS. OF FORCE.
- 6 CHECK STACK EVERY TWO (2) WEEKS TO INSURE ROPES ARE TIGHT.

! WARNING: IT IS DANGEROUS TO INSTALL HAY TARPS ON WINDY DAYS !

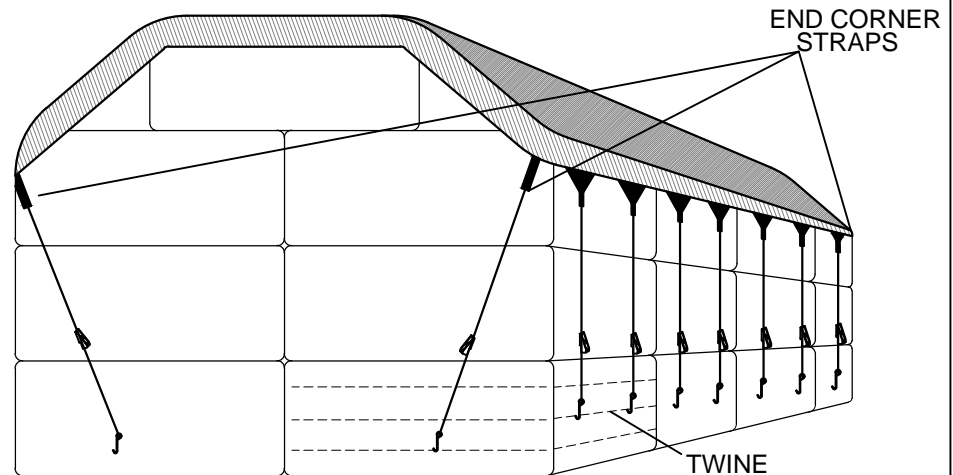
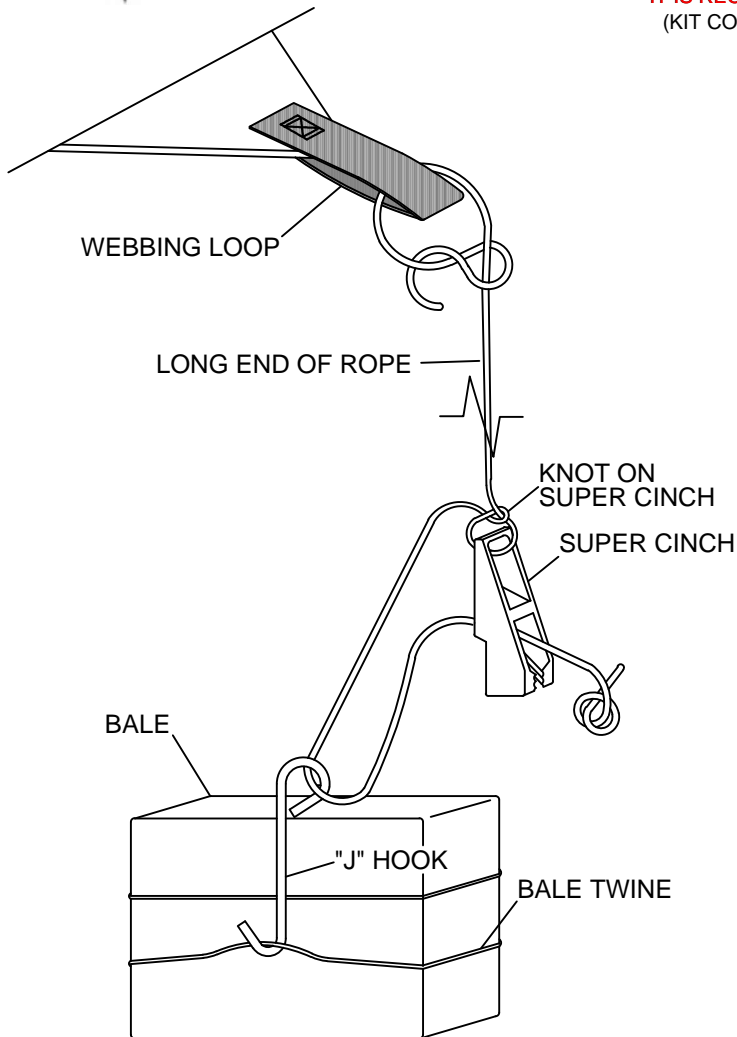

FOR MORE INFORMATION, PLEASE CONTACT OUR CUSTOMER SERVICE REPRESENTATIVES AT [1-800-346-7744](tel:1-800-346-7744) OR SEE OUR WEB SITE AT WWW.INLANDTARP.COM